

The Fatty Acids of Menhaden Oil.

1. Examination of the C_{12} , C_{14} , C_{16} , and C_{18} Fractions by Low Temperature Crystallization Procedures

FRANK A. SMITH^{1,2} and J. B. BROWN

From the Laboratory of Physiological Chemistry, The Ohio State University
Columbus, Ohio

LOW temperature crystallization is a relatively new tool for the investigation of mixtures of fatty acids. This method, developed in this laboratory over the past nine years (1), is based on the differences of the solubilities of the fatty acids in organic solvents at low temperatures. The outstanding advantage of the method is simplicity in that the acids or their esters can be crystallized directly. Further, many of the separations can be carried out more completely than by the use of any of the previously employed procedures. In this report low temperature crystallization has been employed in the study of the lower main fractions of a fish oil, in this instance, menhaden oil.

Relatively few papers dealing with the fatty acid analysis of menhaden oil have appeared in the literature. Twitchell (2, 3) made one of the first attempts to determine quantitatively the amounts of the several carbon series present in this oil. He separated the fatty acids into liquid and solid acids and attempted to evaluate the composition of these mixtures by his method of melting point depression. His results are listed in Table I. Brown and Beal (4) in 1923 reported a study of menhaden oil fatty acids, in which they employed distillation and bromination procedures. The most important contribution of their work was a complete distillation of the methyl esters of the highly unsaturated acids of this oil. McGregor and Beal (5) described the limit of unsaturation of the several carbon series. For example, the C_{22} series may contain acids with as many as six double bonds. Richardson, Knuth, and Milligan (6), as a result of distillation of the mixed esters of the oil, found carbon series from C_{14} to C_{22} . The results of these investigations which attempt to evaluate the amounts of the several carbon series present in the oil are summarized in Table I.

obtained. While our investigation was in progress, the work of Baldwin and Lanham (9) appeared. These authors, employing modern methods, accomplished their analysis by separating the liquid and solid acids of the oil by the lead soap-alcohol method and subsequently distilling the methyl esters of the resultant mixtures of acids. A later paper by Baldwin and Parks (10) described low temperature crystallization of the glycerides of menhaden oil and discussed in detail the nature of the fatty acids. Our data in Table I were the result of distillation of the methyl esters of the hydrogenated acids of this oil; full details of our calculations will follow in a later paper of this series.

The object of the present investigation was, first, to prepare the lower main fractions of the methyl esters of menhaden oil (C_{12} - C_{18} inclusive) and to study their composition by the low temperature crystallization method. The C_{12} and C_{14} fractions are relatively simple mixtures of a saturated and mono-ethylenic ester. The C_{16} fraction contains acids from palmitic up to hexadecatrienoic acids. The C_{18} fraction is a complicated mixture of acids from stearic to octadecatetrenoic. As a result of our work, we have prepared a number of pure esters and acids from the oil for the first time and have been able to secure quantitative values of considerable accuracy for the amounts of some of these acids present in the oil.

Experimental

Through the courtesy of the Procter and Gamble Company of Ivorydale, Ohio, we were furnished with a large specimen of commercial menhaden oil. This oil was of a medium amber color; the iodine number was 182.8, the saponification number, 191.4.

The methyl esters were prepared from 5340 g. of this oil by the usual method and were first roughly separated into five main fractions by distillation from a modified Claisen flask fitted with a 23 cm. Vigreux-type distilling column. The fifth fraction thus obtained was subsequently cut into four sub-fractions by a similar distillation. The first four main fractions and the first sub-fraction of the fifth were then distilled through a highly efficient electrically heated, packed column (11), and, finally, fractions of similar boiling range and refractive index were combined and re-distilled to give the fractions listed in Table II.

It is to be noted that these final fractions represent all of the C_{12} , C_{14} and C_{16} series of this specimen of menhaden oil esters (5142 g.) and, in addition, most of the C_{18} series. The three main fractions of Table II were studied in detail by low temperature crystallization. It should be again noted that the carbon series composition of this specimen of oil, as reported in Table I, is based on distillation of the hydrogenated esters. This is necessary because it is impossible to distil the highly unsaturated esters of the C_{20} and

TABLE I.

Carbon Series of the Fatty Acids of Menhaden Oil

Series	Composition in Per Cent				
	Twitchell (2, 3)	Armstrong and Allen (7)	Stingley (8)	Baldwin and Lanham (9)	This Investi- gation*
C_{14}	9.2	6.0	7.0	14.1	6.9
C_{16}	22.7	31.5	33.0	38.3	30.4
C_{18}	26.7	31.8	28.0	35.8	26.8
C_{20}	22.2	19.0	20.0	8.4	17.5
C_{22}	20.2	12.0	12.0	3.4	10.8
C_{24}	4.0
C_{26}	1.2
Above C_{26}	2.4

*To be described in detail later.

Few details were given by Armstrong and Allen (7) and by Stingley (8) as to how their data were

¹ Presented in partial fulfillment of the requirements for the degree of Doctor of Philosophy in the Graduate School.

² Present address, School of Medicine and Dentistry, University of Rochester, Rochester, New York.

TABLE II.
Analytical Constants of the Final Fractions of the Methyl Esters
of Menhaden Oil*

Wt. g.	M. Mol. Wt. Esters	Iod. No. Esters	Composition in grams				
			C ₁₂	C ₁₄	C ₁₆	C ₁₈	C ₂₀
10.0**	230.6	21.6	3.8	6.2
6.0	241.4	13.2	6.0
254.0**	243.1	2.3	254.0
43.0	249.6	33.0	30.4	12.6
61.0	256.5	46.8	27.7	33.3
1399.0**	267.8	51.2	1399.0
9.2	268.7	48.6	9.0
13.5	272.6	35.4	12.0	1.5
7.0	271.3	120.8	6.6	0.4
16.0	287.5	139.9	4.9	11.1
970.0**	298.5	124.5	970.0
37.0	309.0	203.2	17.0	20.0
28.0	316.9	257.0	4.3	23.7
4.0	302.2	239.1	2.9	1.1
25.0	313.2	241.9	7.4	17.6
91.0	316.6	223.5	15.0	76.0
10.0	318.8	275.3	0.4	9.2
120.0	318.4	250.3	11.6	108.4
91.0	321.0	219.6	91.0
Totals.....			3.8	324.3	1477.4	1041.6	347.0
Per Cent.....			0.1	6.3	28.7	20.3

*From 5340 g. oil, 5142 g. esters.

**These are the fractions studied in this investigation.

C₂₂ series through a column of the type used in this work without considerable loss of material by polymerization, cyclization, and other alteration by long exposure to high temperatures.

Although our principal interest in the fractions of Table II was to be directed towards studying the three main fractions, we have used the data on the entire series of fractions to calculate the yields of the several carbon series present. Thus, from the totals of Table II it is possible to conclude that this specimen of esters contained 0.1% C₁₂, 6.3% (6.9%) C₁₄ and 28.7% (30.4%) C₁₆ esters. Values in parenthesis are those reported in Table I and are based on more complete data.

Investigation of the Heads Fraction. The molecular weight of the heads fraction in Table II indicated the presence of C₁₂ esters. Accordingly this fraction was crystallized as described in Chart I.

CHART I.
Crystallization of the Heads Fraction

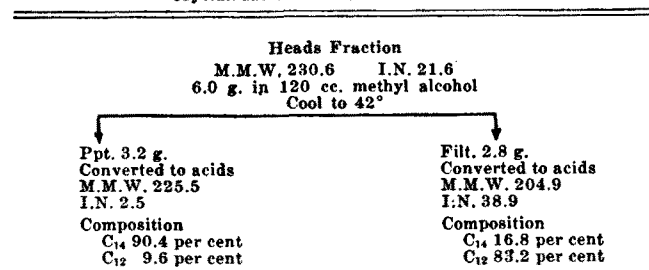

The analytical data in Chart I indicate that the acid of the crystal fraction is principally myristic while the filtrate is chiefly C₁₂ material. If these filtrate acids were 18% tetradecenoic acid and 82% lauric, calculated on the basis of the observed molecular weight, the iodine number of the mixture would approach 20. In view of these considerations the mixture must contain both lauric and dodecenoic acids, together with some tetradecenoic and/or myristic acids. Accordingly, both lauric and dodecenoic acids are present in traces in this oil. The only published report of the presence of an unsaturated C₁₂ acid in menhaden oil is that of Baldwin and Parks

(10), who state that such an acid occurs in traces but give no supporting evidence for their statement.

The C₁₄ Fraction. As indicated in Table II, a pure C₁₄ fraction, 254 g., was available for study and was crystallized as described in Chart II.

CHART II.
Crystallization of the C₁₄ Esters

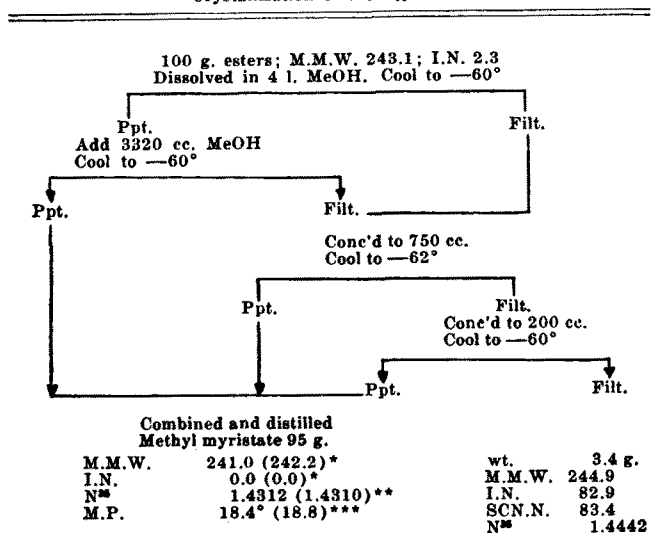

*Theoretical value; in all subsequent charts theoretical values for constants will be included in parenthesis.

**Matil and Longenecker (12).

***Francis and Piper (13).

From 100 g. of this fraction there were isolated 95 g. of practically pure methyl myristate and 3.4 g. of methyl tetradecenoate of about 80% purity. This is a remarkably efficient separation and illustrates the effectiveness of the crystallization method.

The iodine number of the C₁₄ fraction, 2.3, indicates the presence of 2.2% methyl tetradecenoate, or 0.1% of the total esters. The unsaturated material here is entirely monethylenic as is indicated by the fact that the iodine and thiocyanogen numbers are practically identical.

Disruptive oxidation of the unsaturated C₁₄ ester concentrate by the method of Armstrong and Hilditch (14) resulted in the recovery of a dibasic acid, which after recrystallization melted at 95.0-95.5°; mixed melting point with authentic glutaric acid (96.5-96.9°) was 93.4°. It seems likely, therefore, that the unsaturated acid is mainly 5,6-tetradecenoic.

A 5,6-tetradecenoic acid has been isolated from sperm blubber oil by Toyama and Tsuchiya (15), while Armstrong and Hilditch (14) report the presence of 9,10-tetradecenoic acid in a South Georgia whale oil.

The C₁₆ Fraction. As shown in Table II, 1399 g. of pure C₁₆ esters was available for study. The analytical constants are: molecular weight, 267.8; iodine number, 51.2; thiocyanogen number 41.3; polybromide number, 2.5 (m.p. bromides 193-8°; 68.15% bromine); tetrabromide number, 5.8 (m.p. bromides 182-3°; 63.56% bromine). Assuming the polybromide number of the highly unsaturated C₁₆ esters to be 100, the polybromide number of 2.5 for the C₁₆ fraction indicates approximately 2.5% of these highly unsaturated esters in the original fraction. If this highly unsaturated material is assumed to be methyl hexadecatrienoate (iodine number 288.2), it may be

roughly calculated that the C_{16} esters contain 50.9% methyl palmitate, 46.6% methyl hexadecenoate, and 2.5% methyl hexadecatrienoate.

Methyl palmitate of high purity was isolated from the C_{16} fraction according to the scheme indicated in Chart III.

CHART III
Crystallization of the C_{16} Esters
Isolation of Methyl Palmitate

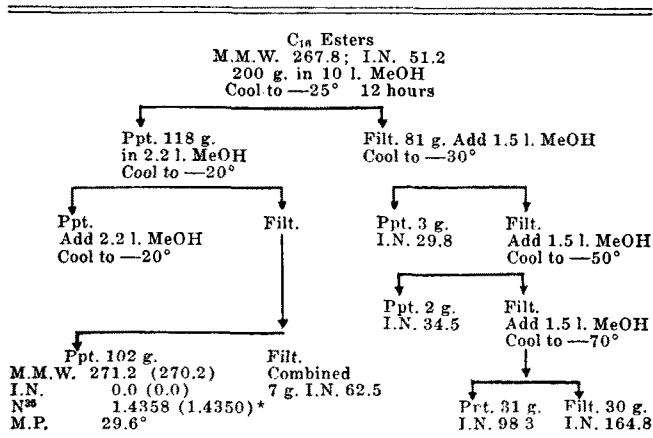

*Mattil and Longenecker (12)

The results in Chart III describe the first isolation of pure methyl palmitate from menhaden oil by direct crystallization procedures. The yield of distilled ester was about 47% of the C_{16} esters crystallized; this yield is slightly low as is indicated by iodine numbers of several of the minor filtrate and crystal fractions in the chart, but is in fair agreement with the 50% palmitate noted in the preliminary calculations above.

CHART IV.
Crystallization of the C_{16} Esters
Isolation of Methyl Hexadecenoate

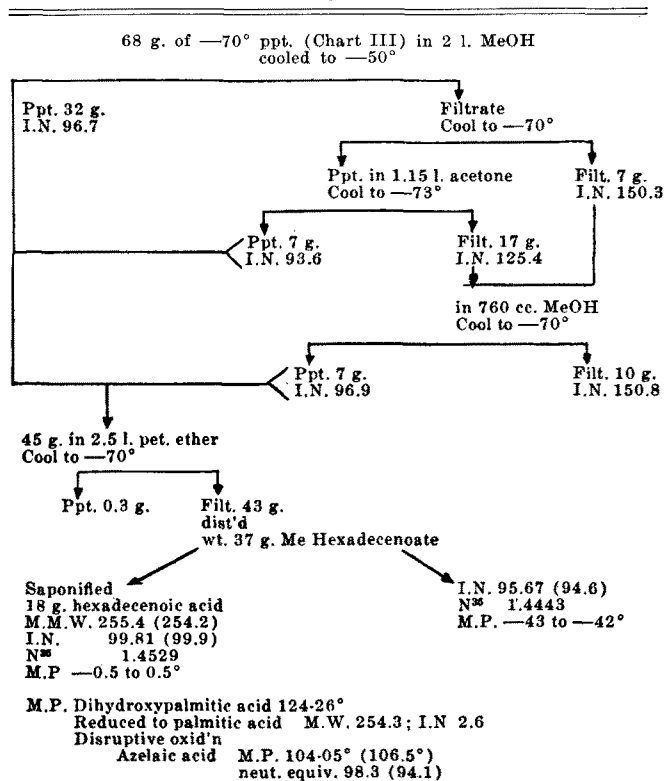

Hexadecenoic acid has been recognized among the fatty acids of marine animal oils since 1854 (17) but has never been isolated in the pure state from these oils. The -70° crystal fraction in Chart III with an iodine number of 98.3 was available for further purification. This material, together with a similar preparation from another series of crystallizations, was treated by the procedure described in Chart IV.

Methyl hexadecenoate of high purity and in good yield was isolated from the C_{16} esters. However, the recovery is not complete since the iodine numbers of certain of the fractions of Chart IV indicate that these fractions contain more methyl hexadecenoate.

A portion of the hexadecenoic acid of Chart IV was hydrogenated to palmitic acid, and a second portion disruptively oxidized with potassium permanganate; the dibasic acid obtained was identified as azelaic acid. These data (Chart IV) show the acid isolated here to be identical with the 9,10-hexadecenoic acid isolated by Armstrong and Hilditch (16) from a South Georgia whale oil. No isomers of this acid have been reported.

In Chart III, the highly unsaturated C_{16} esters were concentrated in the -70° filtrate: I.N. 164.8. A similar filtrate from another series of crystallizations of 360 g. of C_{16} esters amounted to 67.1 g.; I.N. 152.4. This was treated as described in Chart V.

CHART V.
Crystallization of the C_{16} Esters
Investigation of the Highly Unsaturated Esters

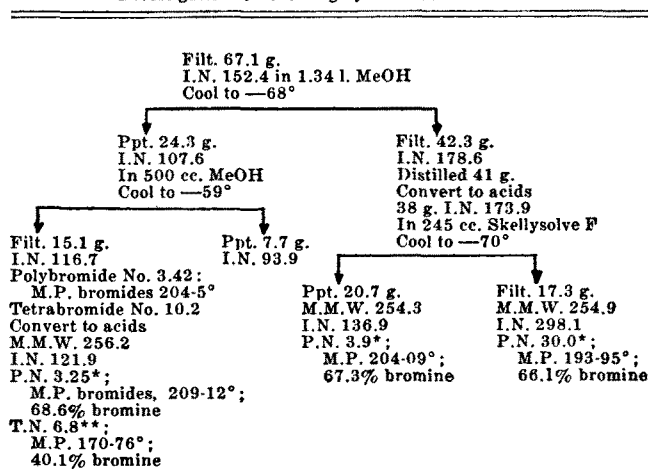

* Ether-insol. bromides.

** Pet. ether-insol. bromides.

The bromine contents of the bromides of the -70° filtrate and precipitate acids indicate the presence of hexadecatrienoic acid together with small amounts of an acid containing more than three double bonds. Calculations based on the theoretical bromine contents of hexabromopalmitic, octabromopalmitic, and octabromostearic acids (65.68, 73.14 and 69.80% respectively) show this bromide mixture (66.1% bromine) to consist of about 95% of hexabromopalmitic acid and 5% octabromopalmitic acid, or of 90% of the former compound with 10% of octabromostearic acids. The iodine number of either mixture, calculated from the bromine content, would be about 300. Since the filtrate acids had an iodine number of 208, obviously other unsaturated acids are present in the mixture, as, for example, hexadecenoic acid, and possibly hexadecadienoic acid. Again, from the poly-

bromide number of this filtrate mixture, 30.0, and the assumed theoretical polybromide number of 100 mentioned previously, the content of polyenic acids in this filtrate can be calculated to be about 30%, which would account for about 90 units of the total iodine number of 208. The iodine number of the residual acids of this mixture constituting 70% of the mixture would be about 160, which strongly indicates that the mixture is mainly hexadecadienoic acid. In view of these considerations it is suggested that polyenic acids of the -70° filtrate consist mainly of hexadecatrienoic acid together with small amounts of a tetrenoic acid. There is some evidence that the remaining acids of this filtrate consist of the dienoic acid of this series and hexadecenoic acid.

This is the first time that concentrates of hexadecatrienoic acid have been prepared by low temperature crystallization procedures. Brown and Beal (4) indicated the presence of this acid in menhaden oil, basing their conclusions on the analytical constants of several fractions obtained by distillation of the highly unsaturated esters. Toyama and Tsuchiya (18) isolated hexadecatrienoic acid (hiragonic acid) by applying bromination-debromination procedures to the highly unsaturated acids of sardine oil prepared by the sodium salt-acetone method. The highly purified hexadecatrienoic acid prepared by them gave a 57% yield of ether-insoluble bromides, melting at about 190° . The bromine content of this material was reported as 65.8% (19).

The C₁₈ Fraction. As shown in Table II, 970 g. of esters was available as representing pure C₁₈ material. The analytical constants are: molecular weight, 298.5; iodine number, 124.5; thiocyanogen number,

90.5; polybromide number, 10.2 (m.p. bromides, 225-29°; bromine content, 66.8%). If it is assumed that the polybromide number of the highly unsaturated C₁₈ esters is 92.7, which is the value reported for methyl arachidonate by Mowry, Brode, and Brown (20), the polybromide number of 10.2 for the C₁₈ fraction indicates the presence of about 11.0% of highly unsaturated esters in this fraction. Calculated on the basis of 66.8% bromine, the polybromides of these highly unsaturated esters consist of 70.2% octa-

CHART VII.
Crystallization of the C₁₈ Esters
Purification of Methyl Stearate

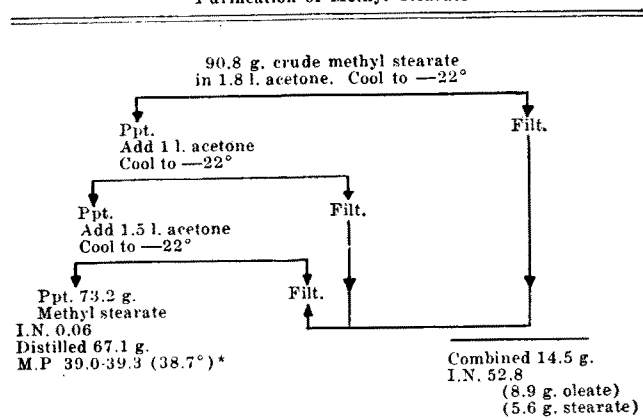

* Francis, F., and Piper, S. H. (13)

CHART VI

Crystallization of the C₁₈ Esters
Separation of the Stearate and Octadecenoate Fractions

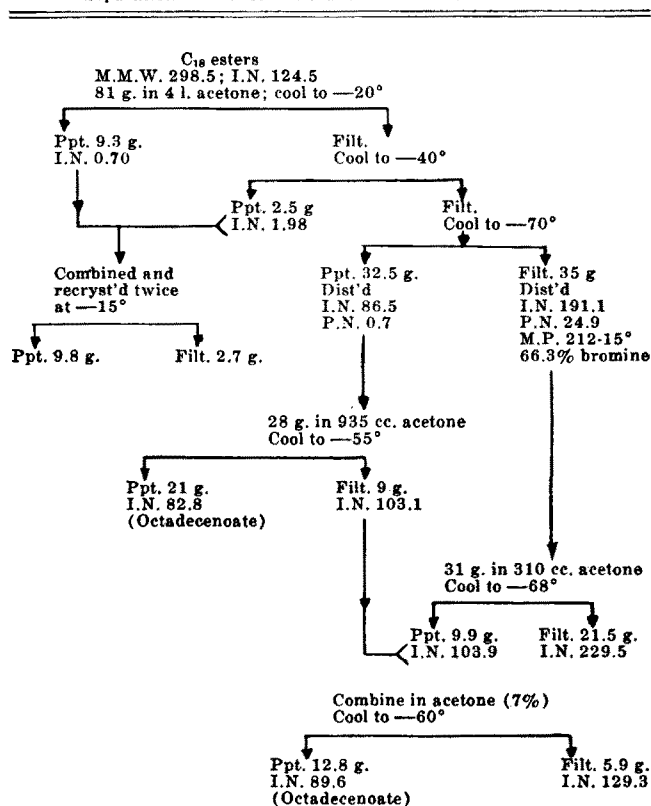

bromides and 29.8% hexabromides. The theoretical iodine number of such a mixture of octadecatrenoic and octadecatrienoic esters would be 311. Hence, these highly unsaturated esters account for about 34.2 units of the total iodine number, leaving 90.3 units still unaccounted for. This figure represents the iodine number of the mixed saturated, mono- and diethylenic esters. The methyl stearate content of the C₁₈ esters was found later by direct crystallization to be about 11.5%.

It is possible from these data to calculate roughly the percentage composition of the C₁₈ fraction to be octadecatrenoate, 6.2; octadecatrienoate, 4.8; octadecadienoate, 27.5; octadecenoate, 50.0; and stearate, 11.5. It is likely, however, that the above values for the tetrenoic and trienoic esters are too low because they are based on the theoretical polybromide number of 92.7. If we increase the tetrenoate and trienoate values by 50% to 9.3 and 7.2, respectively, the dienoate content will be changed to about 13.4% and the octadecenoate to 58.6%. The stearate content is definitely known in either instance. We feel that these latter values are more acceptable, and, based on the data in Table I, the original esters of this oil contain approximately 2.5, 1.9, 3.6, 15.7 and 3.1%, respectively, of the five esters.

Several series of crystallizations, including a total of 683 g. of C₁₈ esters, were carried out in the course of the investigation of this fraction.

The procedures of Charts VI and VII describe first the isolation of crude methyl stearate and then the isolation of pure stearate from several crude preparations.

From 683 g. of C₁₈ esters there were obtained 73.2 g. of pure stearate and several filtrate fractions (Chart

VII) containing an additional 5.6 g. of this ester, or a total of 78.8 g. This amounts to 11.5% of the total C_{18} fraction, or 3.1% of the original esters. Amounts of stearate corresponding to possibly a few tenths of a per cent (C_{18} fraction) have possibly not been accounted for by this method of analysis.

The -55° and -60° precipitates of Chart VI were largely made up of methyl octadecenoate, which was further separated from esters of more unsaturated acids by the procedure of Chart VIII.

CHART VIII.
Crystallization of the C_{18} Esters
Purification of Methyl Octadecenoate

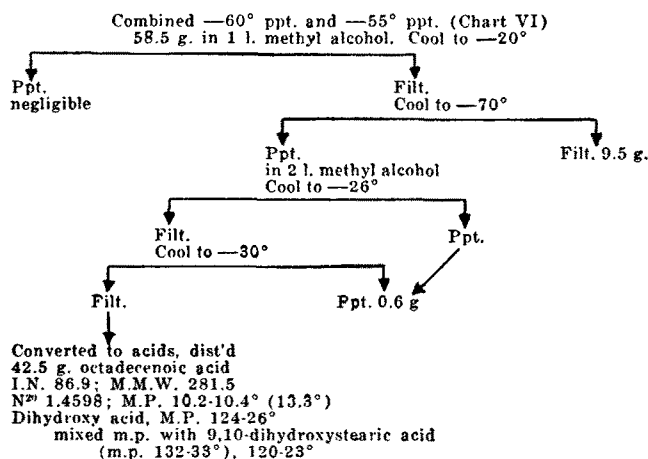

The octadecenoic acid of Chart VIII melted about 3° low for oleic acid; the dihydroxy acid melted 8° lower than authentic dihydroxy stearic acid from olive oil oleic acid. In view of these data, it is suggested that the product is a mixture of oleic acid with one or more octadecenoic acids. Accordingly an attempt was made to resolve this mixture further by a series of recrystallizations from a 2% solution in petroleum ether. The progress of the separation was followed by melting point, and, in some instances, by iodine number determinations. The results are described in Table III.

In Table III the first -63° filtrate (1.0 g.) gave an iodine number higher than that of oleic acid; apparently a small amount of acid with more than one double bond was removed by this step. The features of the data in this table are: nearly pure oleic acid was removed in the -28° precipitate (I.N. 89.4; m.p. $12.5-13.0^\circ$); in general, as the crystallizations proceeded, the crystal fractions rose in melting point, until the last one melted at $12.8-13.0^\circ$; a gradual rise in the melting points of the several filtrate fractions was observed, up to $11.0-11.1^\circ$.

The low melting points of the filtrates cannot be due to contamination with stearic acid since Smith (21) has shown that, while 3.5 mol. per cent of stearic acid in oleic acid lowers the melting point to 13.1° , a mixture of 4.8 mol. per cent stearic acid and 94.2 mol. per cent oleic acid melts at 30.2° . The melting point of the final precipitate was $12.8-13.0^\circ$. The dihydroxy derivative of this fraction melted at 132° which indicates that the precipitate oleic acid is almost free of the isomeric acid, but on the basis of iodine number it contains 5% stearic acid.

Filtrates, the melting points of which were within the range -1.5 to 5.5° , were now combined and crystallized from a 2% solution in petroleum ether at -65° . The filtrate (2 g.) was partially liquid at -20° ; the crystal fraction (8.9 g.) melted at -3.4 to 0° . The dihydroxy derivative of a small portion of this material was prepared and recovered in 18% yield; its melting point was $120.2-120.7^\circ$. Upon recrystallizing this material from alcohol, the crystals melted at $117.7-18.8^\circ$; crystals recovered from the mother liquors melted at $119.8-20.3^\circ$. Six grams of the -65° precipitate (m.p. $-3.4-0^\circ$) were now oxidized to the dihydroxy derivative; a total of 3.73 g. of crude product was recovered, corresponding to a yield of 62%. Upon recrystallizing from alcohol 3.3 g. melting at $84.1-85.6^\circ$ was obtained; crystals of melting point $91.5-93.0^\circ$ were recovered from the mother liquors. Both fractions were extracted with petroleum ether and repeatedly crystallized until a constant melting point of $95.0-95.4^\circ$ was reached for both fractions, after which they were recombined; 1.2 g. of material was obtained, corresponding to 20% yield. Approximately 0.2 g. of material of melting point 63° was recovered from the petroleum ether extracts; this is quite evidently crude stearic acid, present as a contaminant.

We believe our data on the nature of the octadecenoic acids of menhaden oil indicate definitely the presence of oleic acid, together with certain amounts of isomeric octadecenoic acids. By repeated crystallizations of these mixed acids we were able to separate them. The main product of this separation was shown to be a mixture of ordinary oleic acid with about 5% stearic acid while the other products yielded a dihydroxy derivative which melted approximately 37° lower than ordinary 9,10-dihydroxystearic acid.

TABLE III.
Recrystallization of the Octadecenoic Acids of Menhaden Oil

Fraction		Yield g.	Iodine No.	M.P. °C.
Original		35.0	86.9	10.2-10.4
-63° filt.	1.	1.0	109.5	-5.5 to -5.0
	2.	1.6	88.3	-1.5 to 0.5
	3.	2.5	86.8	1.7-2.3
-63° ppt.	1.	29.8	85.6	11.3
ppt.	1. recrystallized at -28°			
-28° ppt.	2.	8.4	89.4	12.5-13.0
-28° filtrate recrystallized at -60°				
-60° filt.	4.	1.1	88.4	2.0-2.5
	5.	1.0	87.0	2.5-3.1
	6.	0.8	88.1	2.7-3.5
-60° ppt.	7.	0.9	87.6	2.2-2.7
	3.	17.4	86.7	12.2-12.3
Combined -28° and -60° ppts. recrystallized at -60°				
-60° filt.	8.	0.9
	9.	0.5	3.5-4.0
	10.	0.5	3.7-4.2
	11.	0.6	3.5-4.0
	12.	0.3	4.5-5.5
	13.	0.3	0.0-1.0
-60° ppt.	4.	20.7	83.9	12.7-13.0
ppt.	4. recrystallized at -51°			
-51° filt.	14.	0.7	8.0-9.0
	15.	0.4	10.0-11.0
-51° ppt.	5.	19.2	86.0	12.7-13.0
ppt.	5. recrystallized at -60°			
-60° filt.	16.	0.2	8.8-10.0
	17.	0.3	8.8-10.0
	18.	0.2	10.0-10.5
-60° ppt.	6.	17.7	85.3	12.5-12.9
ppt.	6. recrystallized from acetone at -62°			
-62° filt.	19.	0.6	8.6-9.3
	20.	0.5	11.0-11.1
-62° ppt.	7.	16.0	85.5	12.8-13.0

CHART IX.
Crystallization of the C₁₈ Esters
Separation of the Highly Unsaturated Filtrate Fractions

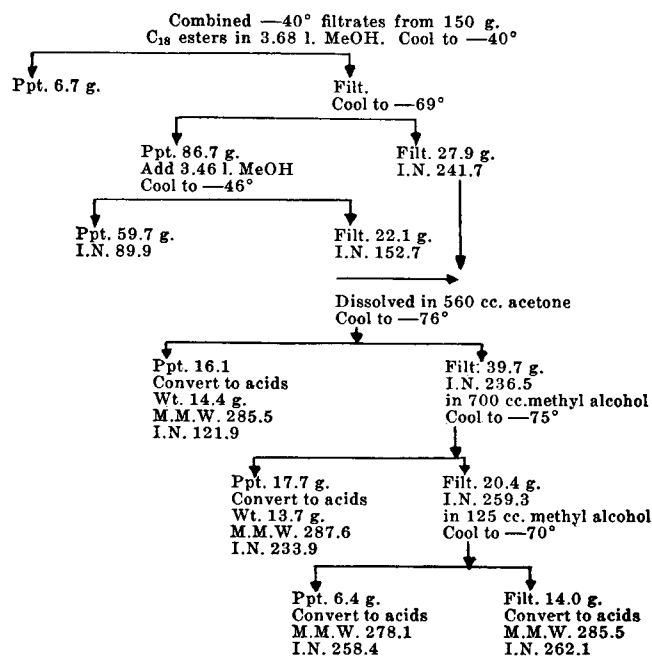

An isomeric octadecenoic acid was first reported in aquatic fats by Moore (22), who isolated such an acid from whale oil and stated that the dihydroxy derivative melted at 124-25°. These findings were confirmed by Armstrong and Hilditch (16), who submitted their dihydroxy derivative (m.p. 125-26°) to disruptive oxidation with potassium permanganate and showed that the acid was probably 11,12-octadecenoic acid. More recently, Baldwin and Parks (10) reported the preparation of a dihydroxystearic acid melting at 115-6° from the C₁₈ acids of menhaden oil. Disruptive oxidation of their dihydroxy acid with potassium periodate indicated the presence of both oleic and 11,12-octadecenoic acids.

The highly unsaturated acids of the C₁₈ main fraction were next investigated. The -40° filtrates from 150 g. of this fraction were prepared as described in Chart VI and treated by the procedure

described in Chart IX. The final -70° filtrate from this series of crystallizations was combined with a similar product from a second similar series of crystallizations.

In Chart IX, the -40° precipitate represents stearate and the -46° precipitate octadecenoate. A number of concentrates of high iodine number, described in Chart IX, and several from the second series of operations were studied by the bromination method. The results are found in Table IV. The yield of ether insoluble bromides (polybromide number) is indicative of trienoic and more highly unsaturated acids. The tetrabromide number was found by brominating in cold petroleum ether. In certain instances the petroleum ether-insoluble bromides were separated by extraction with ether, concentrating the ether extract and precipitating with petroleum ether.

Examination and study of the data in Table IV reveal that none of the fractions upon bromination of the corresponding acids yielded pure tetrabromo-, hexabromo-, or octabromostearic acids. However, we believe there are definite indications of the presence of octadecadienoic and octadecatrienoic acids in addition to the octadecatetrenoic acid present in the C₁₈ fraction. Low temperature crystallization has been only partly successful in separating these acids of two to four double bonds. The presence of octadecadienoic acid is suggested by the bromides obtained from the second -76° precipitate of Table IV. In this instance, the petroleum ether-insoluble bromides were extracted with ether and the soluble bromides, presumably tetrabromides, were re-precipitated to give a product melting at 174-9° and containing 57.94% bromine. Several of the bromide preparations in Table IV analyze as mixtures of hexa- and octabromides of acids of this series.

Octadecatetrenoic acid (in the earlier literature, clupanodonic acid) was first shown to be present in menhaden oil by Brown and Beal (4). Baldwin and Parks (10) also demonstrated the presence of this acid in menhaden oil by brominating the filtrate acids prepared by a single crystallization of the C₁₈ esters. These bromides, melting at 230°, were found to contain 69.6% bromine. An octadecatetrenoic acid has also been isolated from sardine oil by Toyama and Tsuchiya (23). The acid prepared by these authors yielded 58% of ether-insoluble bromides of melting point about 220°, and containing 69.7% bromine.

TABLE IV.
Analytical Constants for the Bromine Derivatives of Certain Fractions of Chart IX.

Fraction	Ether-Insol. Bromides			Petroleum Ether-Insol. Br.			Extracted Br.	
	P. N.	M. P. °C.	Br. %	T. N.	M. P. °C.	Br. %	M. P. °C.	Br. %
-76° ppt.....	6.4	241-42	66.45	15.2	225-27	65.44		
-65° ppt.**.....	5.3	237-38	65.72	33.9	216-17	60.5	177-78* (residue, 112-17)	64.48
-76° ppt.**.....	10.1	226-30	64.75	46.1	140-43	58.94	174-79* (residue, 215-18)	57.94
-75° ppt.....	27.9	237-39	67.75	14.5	240-41	66.8	64.09
-70° ppt.....	31.2	239-40	68.56	24.5	240-42	66.75	125-40*	67.27
-70° filt.***.....	36.4	239-41	67.75	18.0	236-37	68.89

*Prepared by extracting petroleum ether-insol. bromides with ether, concentrating extract to small volume, adding cold petroleum ether and allowing to stand at 0° overnight.

**From similar crystallizations.

***-70° filt. of Chart IX and -70° filt. of comparable molecular weight and iodine number from similar crystallization.

We are greatly indebted to the Procter and Gamble Company, Ivorydale, Ohio, for the financial assistance by which it was possible to carry on this investigation through an open Fellowship in the Ohio State University Research Foundation.

Summary

The methyl esters of a specimen of menhaden oil have been fractionated in an efficient still. The C_{12} , C_{14} , C_{16} , and C_{18} main fractions have been studied, mainly by low temperature crystallization procedures. The oil has been shown to contain traces of lauric and dodecenoic acids. The C_{14} acids are made up of 2.2% tetradecenoic acid and 97.8% of myristic; based on the whole ester composition of Table I, these values amount to 0.1 and 6.8%, respectively. The C_{16} acids are palmitic, 50.9%; hexadecenoic, 46.6%; and hexadecatrienoic (including a small amount of tetrenoic acid) 2.5%, or based on the whole esters, 15.5, 14.1 and 0.8%, respectively. A very rough calculation of the composition of the C_{18} fraction gives the following results, values based on the whole esters being included in parenthesis: stearic, 11.5 (3.1); octadecenoic, 58.6 (15.7); octadecadienoic, 13.4 (3.6); octadecatrienoic, 7.2 (1.9); and octadecatetrenoic, 9.3% (2.5%). In the course of this investigation the following acids and their methyl esters were isolated from the oil by crystallization procedures; myristic, tetradecenoic (80%), palmitic, hexadecenoic, stearic, and oleic. Evidence was presented that the octa-

decenoic acids of this oil were a mixture of oleic acid with isomeric acids of this series, a finding which is in agreement with a recent report from this laboratory (11), describing the multiple nature of the octadecenoic acids of a number of animal fats.

REFERENCES

1. Brown, J. B., Chem. Rev. 29, 333 (1941).
2. Twitchell, E., Ind. Eng. Chem. 6, 564 (1914).
3. Twitchell, E., *Ibid.* 9, 581 (1917).
4. Brown, J. B. and Beal, G. D., J. Am. Chem. Soc. 45, 1289 (1923).
5. McGregor, R. R. and Beal, G. D., J. Am. Chem. Soc. 48, 3150 (1926).
6. Richardson, A. S., Knuth, C. A. and Milligan, C. H., Ind. Eng. Chem. 17, 80 (1925).
7. Armstrong, E. F. and Allen, J. F., J. Soc. Chem. Ind., 43, 216T (1924).
8. Stingley, D. V., Ind. Eng. Chem. 32, 1217 (1940).
9. Baldwin, W. H. and Lanham, W. B., *Ibid.* 13, 645 (1941).
10. Baldwin, W. H. and Parks, L. E., Oil and Soap 20, 101 (1943).
11. Millican, R. C. and Brown, J. B., J. Biol. Chem. 154, 437 (1944).
12. Mattil, K. F. and Longenecker, H. E., Oil and Soap 21, 16 (1944).
13. Francis, F. and Piper, S. H., J. Am. Chem. Soc., 61, 577 (1939).
14. Armstrong, E. F. and Hilditch, T. P., J. Soc. Chem. Ind. 44, 43T (1925).
15. Toyama, Y. and Tsuchiya, T., Bull. Chem. Soc., Japan 10, 563 (1935).
16. Armstrong, E. F. and Hilditch, T. P., J. Soc. Chem. Ind. 44, 180T (1925).
17. Hofstadter, P. G., Ann. 91, 177 (1854).
18. Toyama, Y. and Tsuchiya, T., Bull. Chem. Soc. Japan 4, 83 (1929).
19. Toyama, Y. and Tsuchiya, T., Bull. Chem. Soc. Japan 10, 192 (1935).
20. Mowry, D. L., Brode, W. R. and Brown, J. B., J. Biol. Chem., 142, 671 (1942).
21. Smith, J. C., J. Chem. Soc., (1939) 974.
22. Moore, C. W., J. Soc. Chem. Ind., 38, 320T (1919).
23. Toyama Y. and Tsuchiya, T., Bull. Chem. Soc., Japan. 10, 323 (1935).

Determination of Moisture in Peanut Kernels

CARROLL L. HOFFPAUIR

Southern Regional Research Laboratory¹
New Orleans, Louisiana

THE official methods of analysis of the American Oil Chemists' Society (1) for peanut kernels specify two oven-loss methods for the determination of moisture. Original moisture on the sample as received is determined by the loss in weight on heating a 50-gm. sample of kernels, after grinding in a Universal food grinder using a 12-tooth blade, for one hour at 130° C. in a forced draft oven. Second moisture is determined on the sample used for the determination of oil and ammonia. This sample is prepared by heating the kernels for 20 minutes at 130° C. to dry them partially and then grinding with a Universal food grinder using a peanut butter blade. The loss in weight of a 5-gm. sample of this material heated for 2 hours at 101° C. in either a forced draft or a convection oven gives second moisture. It is doubtful that these two oven procedures for first and second moisture reduce the sample to the same degree of dehydration. It is presumed in these procedures that there is no change in moisture content during the original grinding and other handling of the samples prior to weighing the analytical samples. If the moisture content of the peanuts is high, loss in original moisture might occur, or if the content is low, moisture

could be gained from the atmosphere. That this is actually the case has been demonstrated by grinding weighed samples of whole peanuts in the shell through the Universal food grinder using the 12-tooth blade. Care was used to avoid loss of material and the ground material was weighed. This procedure gave losses, assumed to be moisture, of 1.52 and 1.39% for two different samples. The ground samples contained 8.21 and 8.38% moisture, respectively, as determined by heating at 130° C. for one hour in a forced draft oven. Original moisture should therefore be determined on the whole rather than on ground kernels.

The determination of the moisture content of biological material by oven loss in weight methods is a purely empirical procedure, governed by the following variables: 1. temperature, 2. pressure, 3. time, and 4. size and surface of the sample. Hence, in determining moisture by oven loss in weight methods, it is necessary to learn what combinations of these variables may be used to give satisfactory and reproducible results without being influenced by oxidation, decomposition, volatilization of non-moisture constituents, or a combination of these factors. These considerations indicate it is highly improbable that control and inspection methods may be developed to give the true moisture contents. Consequently, suitable oven

¹ One of the laboratories of the Bureau of Agricultural and Industrial Chemistry, Agricultural Research Administration, U. S. Department of Agriculture.